

RS.H011



REV

MODEL: NSR250R

YEAR: ALL

Est.inst.time: 45-60 min

SHIFT SIDE

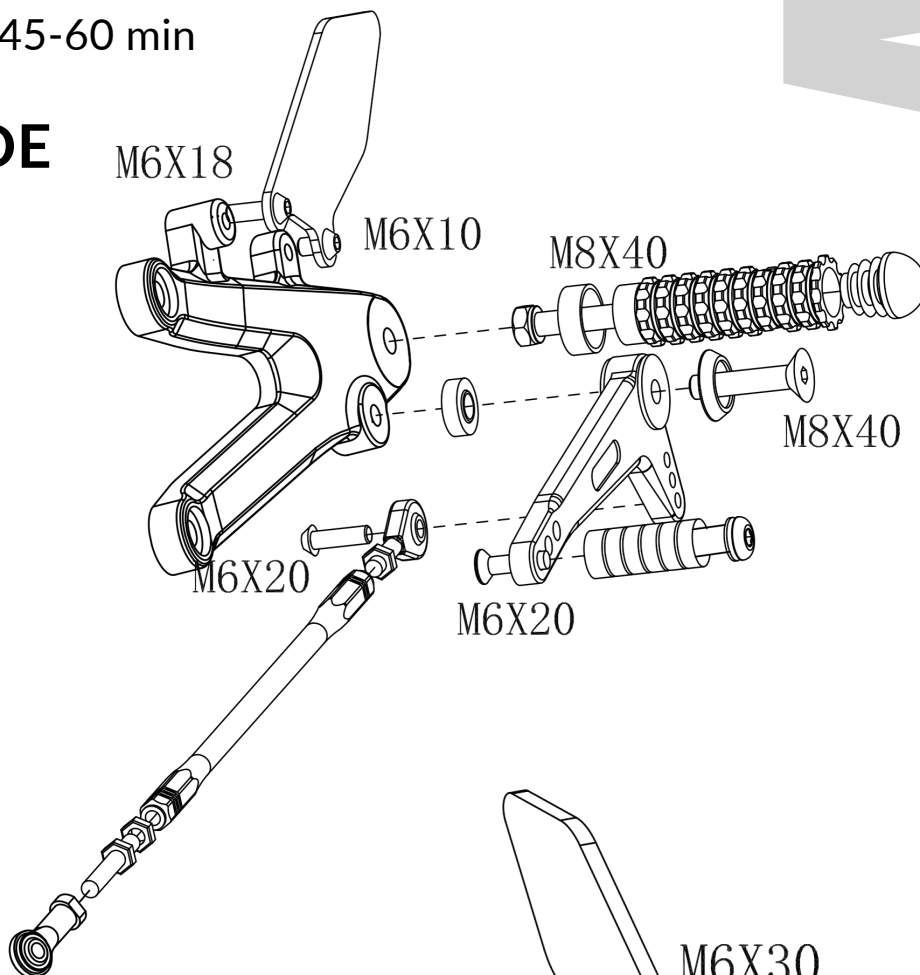

BRAKE SIDE

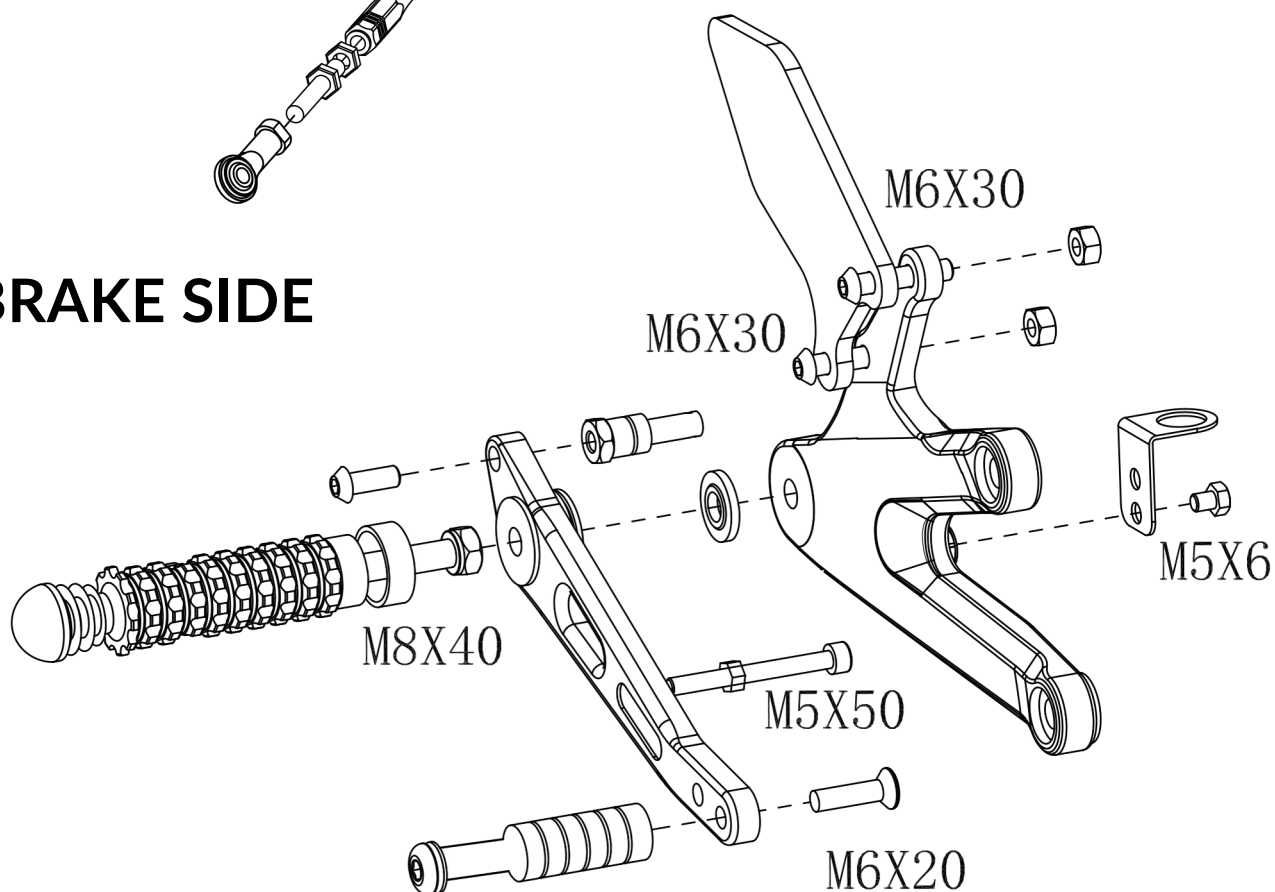

BEFORE YOU START

Tools Required for installation

- Hex keys (M5,M6,M8)
- Medium-strength threadlocker (Loctite® 243) Blue
- Torque wrench

Preparation

- Support the motorcycle securely.
- Completely remove the OEM rearsets.Keep OEM components.
- Clean all mounting threads before installation.

⚠ Important

- Do not fully tighten any fasteners until all adjustments are completed.
- Moto-Tron rear sets are pre-assembled for reference only.All fasteners must be removed & apply threadlocker prior to final installation.Failure to do so may result in fasteners loosening due to vibration.

Adjustment Guidelines

- Footpeg Position: Begin from an neutral position. Adjust until your thighs can comfortably and securely grip the fuel tank, with the knee and ankle forming an approximate 90-degree angle for proper rider ergonomics.
- Shift Lever : Adjust for comfortable ankle range of motion,ensure smooth and stable shifting and return movements.the angle between the shift linkage and joint (rod end) should be as close to 90° as possible.
- Brake Lever : Ensure free return and proper brake light operation

Final adjustments should be made according to rider preference.

Final Safety Check

Before riding, confirm:

- All fasteners are tightened
- Threadlocker applied and allowed to cure for at least 30 minutes.
- Ensures smooth shifting and braking operation.
- Brake light functions correctly (if applicable)
- No interference with fairings, exhaust, or side stand
- Recheck all fasteners after 50-100 km of riding.

⚠ Disclaimer

If you are unsure about any step of the installation, we recommend professional installation.

Support & Updates

For the latest installation guide, videos, and updates, please scan the QR code.

Website: www.moto-tron.ca

Support: General@moto-tron.ca

Thank you for choosing Moto-Tron Racing

Enjoy your ride ❤️

